

# *ASC IsoDamp Guide to High Performance Soundproofing*



## *Table of Contents*

<b>Introduction</b>	Page 2
<b>Ceiling Installation</b>	Page 3
Perimeter Gasket	Page 4
Resilient Channel	Page 5
Installing First Layer of Sheetrock	Page 6
Applying WallDamp	Page 7
Installing Second Layer of Sheetrock	Page 8
<b>Wall Installation</b>	Page 9
Wall Bearing Felt	Page 10
Perimeter Gasket and RC Pads	Page 11
Resilient Channel	Page 12
Installing First Layer of Sheetrock	Page 13
Applying WallDamp	Page 14
Installing Second Layer of Sheetrock	Page 15
<b>Contractor Options</b>	Page 16



## Introduction: Easy as 1, 2, 3

Welcome to ASC IsoDamp guide to high performance soundproofing. This guide will show you how it's done in basically three easy steps. Step 1 is **SITE PREP** such as insulation, HVAC ducts and vents, perimeter blocking, and electrical box placement. Step 2 is **INSTALL SUSPENSION SYSTEM** of gasket, RC Pads, and resilient channel\*. Step 3 is **INSTALLING THE SHEETROCK** with WallDamp sandwiched between.

This system is based on the resilient channel method of soundproofing, a well proven technique that has been in use for over 50 years. The ASC IsoDamp soundproofing system is an improvement on the resilient channel system because we add damping to the assembly.

In all cases, **always be sure to follow your local building codes**, regardless of what we suggest in this guide. The ASC IsoDamp Soundproofing System uses two layers of dissimilar sheetrock, one being regular 1/2" gypsum wallboard, the other being 1/2" "green-board". Its up to you if you want to use thicker material.

Regardless, screw length and type is critically important to the success of your project. You **MUST** calculate the right length to achieve secure sheetrock attachment. Be sure to study this illustration below for proper screwing guidelines when attaching drywall.

### Metal

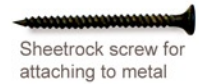

### Wood

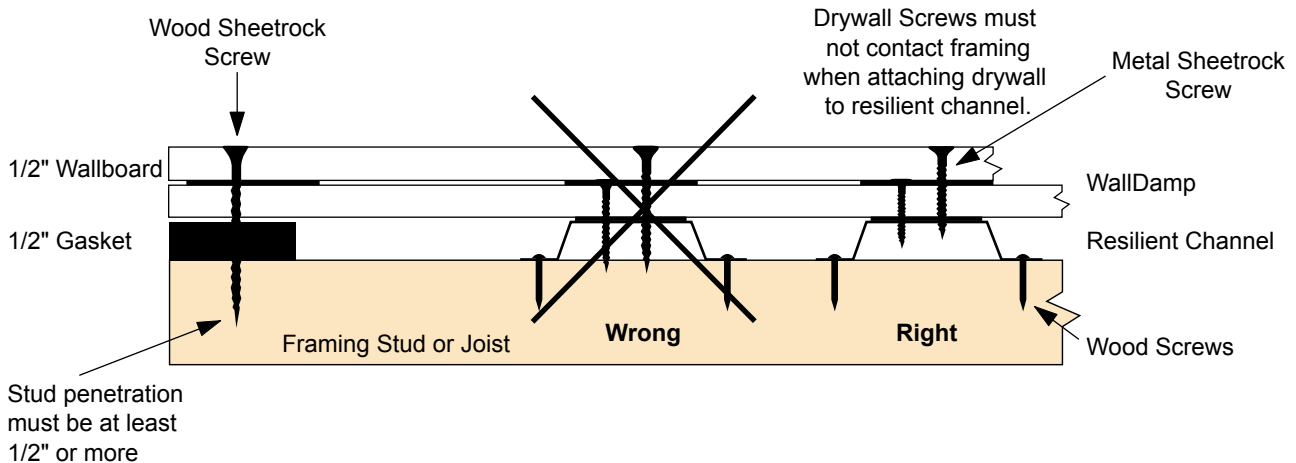
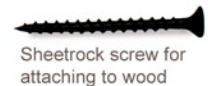

## WallDamp Installation Technique

WallDamp comes with a double sided adhesive which is completely non-toxic. It is a molecular migration type adhesive which takes time to fully stick to where ever it is placed. That said, the adhesive is there only to help you position it properly before screwing in the resilient channel or sheetrock. **The most important thing to understand is that, when placed in position, it will only stay there for a few hours before falling to the ground.** Don't position WallDamp pads and squares the day before. It's better to do the install in manageable stages or in steps that don't rely on WallDamp to remain in place over night.

Some installers prefer to use a mallet to help persuade the WallDamp to "stick around" longer. Once you get started, you'll see what works for you.



\* For questions about installing resilient channel, visit USG's website at [www.usg.com](http://www.usg.com)

# IsoDamp Ceiling Install

(Contractors see page 16)

## Materials We Supply

**WALLDAMP SQUARES**



**WALLDAMP STRIPS**



**RC PADS**



**ACOUSTICAL SEALANT**



**dRC-2  
Damped Resilient  
Channel for Ceilings**



**PERIMETER  
GASKET**



## Required Materials You Supply

**CONSTRUCTION  
ADHESIVE**



**INSULATION  
BLANKET**



**TACK  
NAILS**



**MASKING  
TAPE**



**WIRE INSULATION  
SUPPORTS**



**1-1/4" & 1-3/4"  
DRYWALL SCREWS**



**3/8" TYPE S PAN  
HEAD SCREWS**



**1/2" REGULAR  
WALLBOARD**

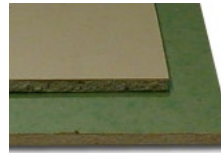

**1/2" MOISTURE RESISTANT  
GYPSUM WALLBOARD**

**SPRAY  
ADHESIVE**



**MALLET WITH  
PADDING**



## IsoDamp Ceiling Prep

### Position ceiling fixtures:

It's a good idea to plan ahead before you begin your IsoDamp installation. The final ceiling thickness in the system is roughly 1-5/8" from the face of the joists. Be sure to place pot lights, HVAC vents and other junction boxes accordingly.

When installing the wallboard in the IsoDamp system, leave a 1/4" gap around any fixtures. Later, these gaps will be filled with acoustical sealant. This is the same method used for sealing around the wall/ceiling perimeter edges.

When you have finished installing the system, apply another bead of acoustical sealant to the edges of each fixture, prior to applying any faceplates or coverings.

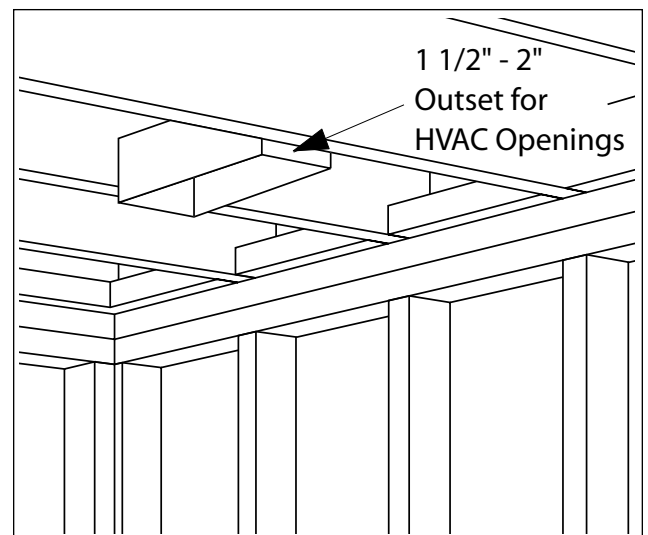

**HVAC VENT INSTALLATION**

# Ceiling Installation

## Install Perimeter Gasket

[1] With a urethane panel adhesive such as Liquid Nails™, glue **Perimeter Gasket** around perimeter of ceiling (Fig. 2A). Use tack nails (if needed) as extra holding strength while the adhesive dries.

[2] Determine placement of dRC2 resilient channel using our placement guide on page 5 (Fig. 3A).

[3] Remove release paper on one side of 1-1/2" x 3" **RC Pads** and apply them to the face of the ceiling joists where **dRC2**'s will be screwed on (Fig. 2A). Be sure to read **Install Technique** information above. Remove remaining release paper.

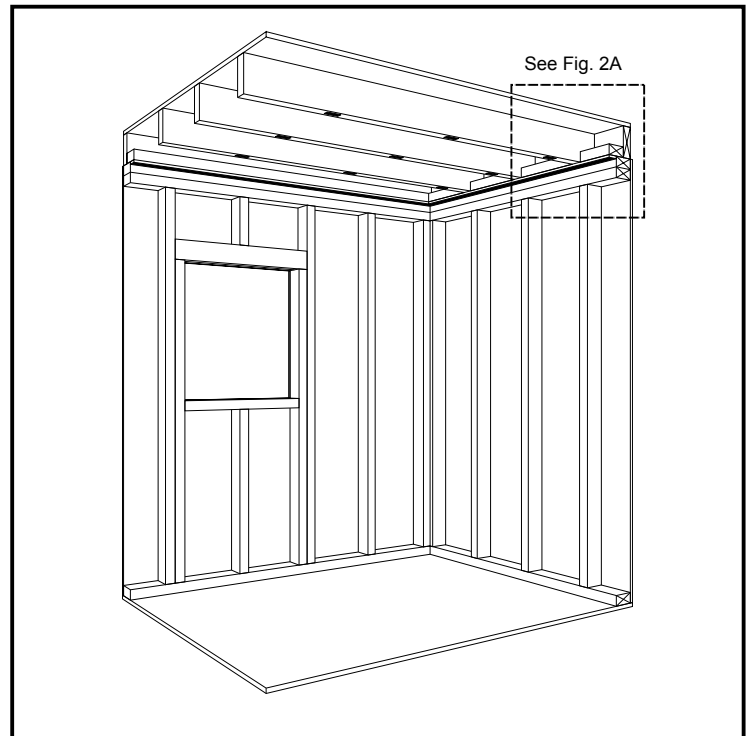

Fig. 2 CEILING INSTALLATION

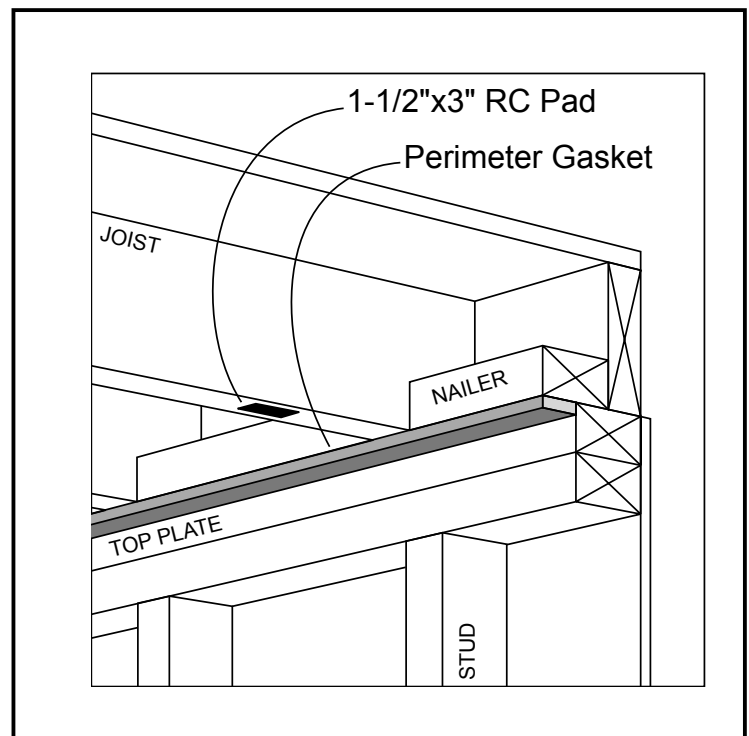

Fig. 2A DETAIL

**Install Insulation**

[4] Press insulation blanket (not shown) into joist cavity. The paper or foil backing should either be glued to the ceiling with spray adhesive or it should be removed. If necessary, use wire insulation supports every 12" to 16" to hold up the blanket.

**Install dRC2 Resilient Channel**

[5] Fasten **dRC-2s** perpendicular to ceiling joists with 1-1/4" drywall screws at each joist in both flanges.

Channel spacing should be no more than 12" on centers. Keep end Channels parallel to wall at least 12" from the wall /ceiling corner. Channel ends should overhang no more than 6" from final joist. (Fig. 3A)

Splice channels directly over joists by overlapping (not butting) at least 1-1/2" and driving screws through both flanges into the joists (Fig. 3B). If channel overlap falls between joists, overlap channels at least 6" and fasten both channels near ends with 3/8" Type S Pan Head Screws. (Fig. 3C)

**TIP:** Mark the location of the joists and the **dRC-2s** on wall's top plates with masking tape at the ends of each joist. This will be helpful for later installation.

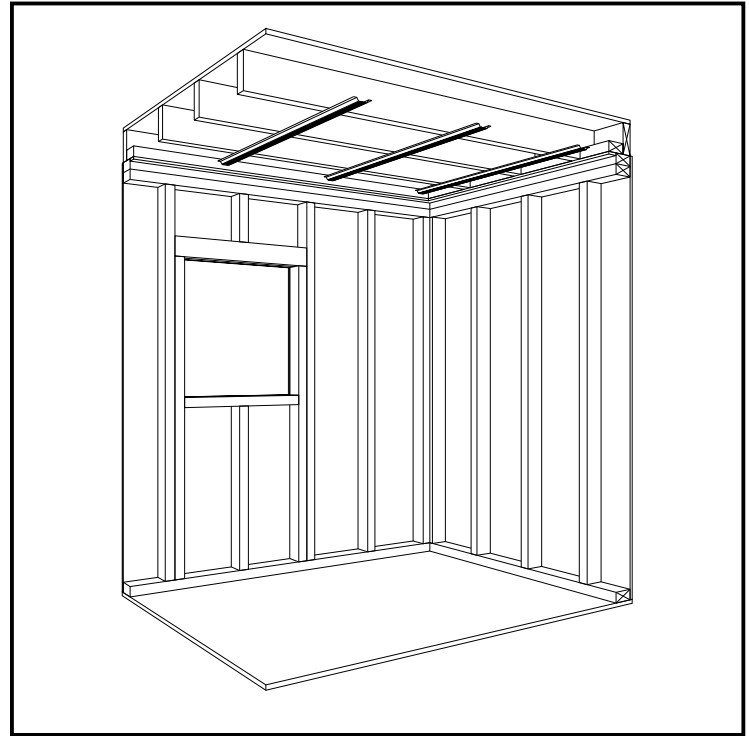

**Fig. 3 CEILING INSTALLATION (cont'd)**

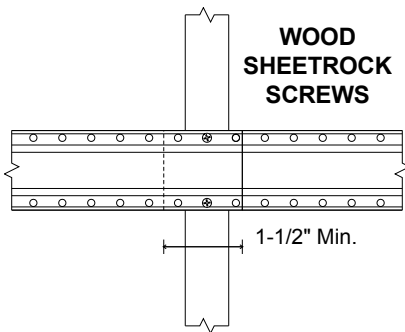

**Fig. 3B SPLICE CHANNELS OVER JOIST**

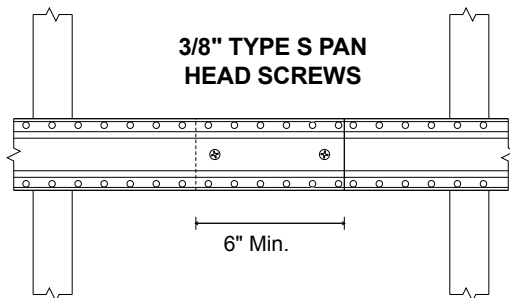

**Fig. 3C SPLICE CHANNELS BETWEEN JOISTS**

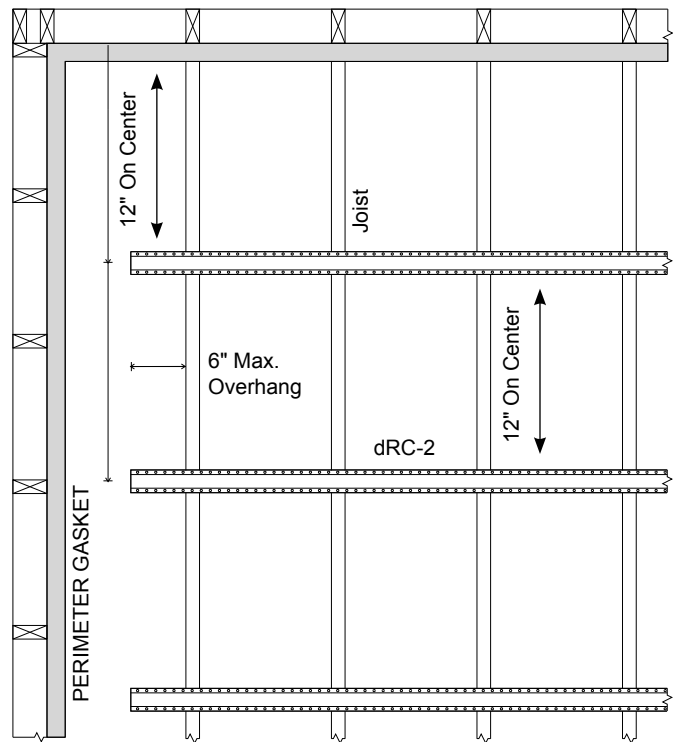

**Fig. 3A CEILING PLAN**

**Prepare Perimeter Gaskets**

[6] Apply 1/4" bead of panel adhesive to face of the installed **Perimeter Gasket** strips.

[7] Snap chalk lines on the wallboards to mark the location of the **dRC-2s** and the joists.

**Install First Layer of Sheetrock**

[8] Attach 1/2" Moisture Resistant wallboard perpendicular to **dRC-2s** with 1-1/4" drywall screws for metal, 12" (max.)\* on centers. Avoid driving the screws to joists by keeping the screws a minimum 2" distance from joists. (Fig. 4A)

**Note:** Place the green side of the first layer board toward the framing, brown side facing out. The green side has tapered edges which prohibit adequate contact with WallDamp strips.

At the perimeter, use sheetrock screws for wood to screw wallboard to ceiling nailer 12" (max.) on centers through **Perimeter Gasket** strips and at least 1/2" or more into support blocking.

A 1/4" gap should be kept between ceiling wallboard and the top plates. Apply **Acoustical Sealant** to seal the gap.

[9] Decide and visualize the layout for the second layer wallboard. We recommend this layer should go the same direction as the first layer (perpendicular to **dRC-2s**). Joints between the two layers should be staggered, and centered over WallDamp Squares). Identify and mark where the joint seams will be.

**Note:** If the second layer of wallboard needs to be orientated parallel to the **dRC-2s** (opposite the first layer), be sure to space the **dRC-2s** so the second layer wallboard seams align centered over the **dRC-2s**.

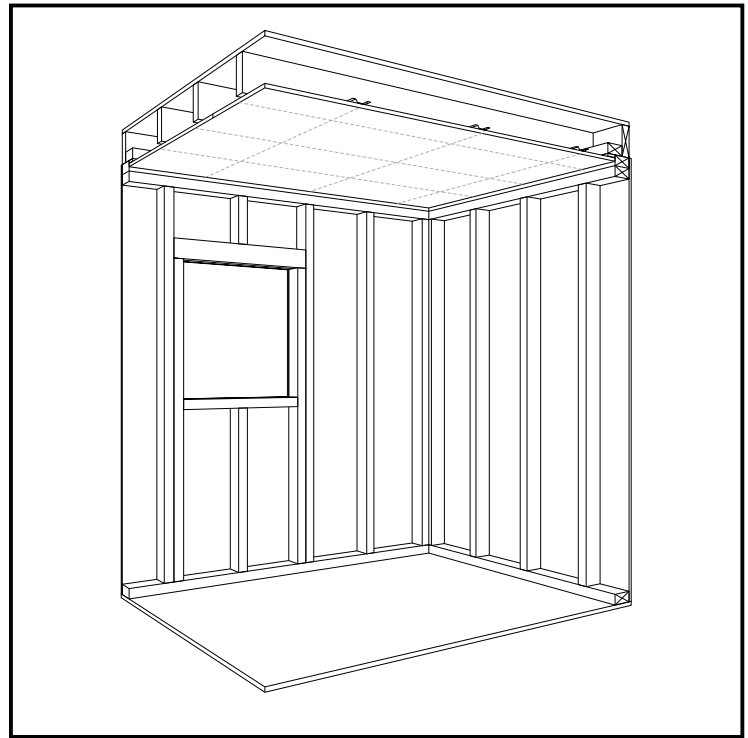

Fig. 4 CEILING INSTALLATION (cont'd)

\* **Always follow local building codes!**

**Avoid Driving Sheetrock Screws into Framing**

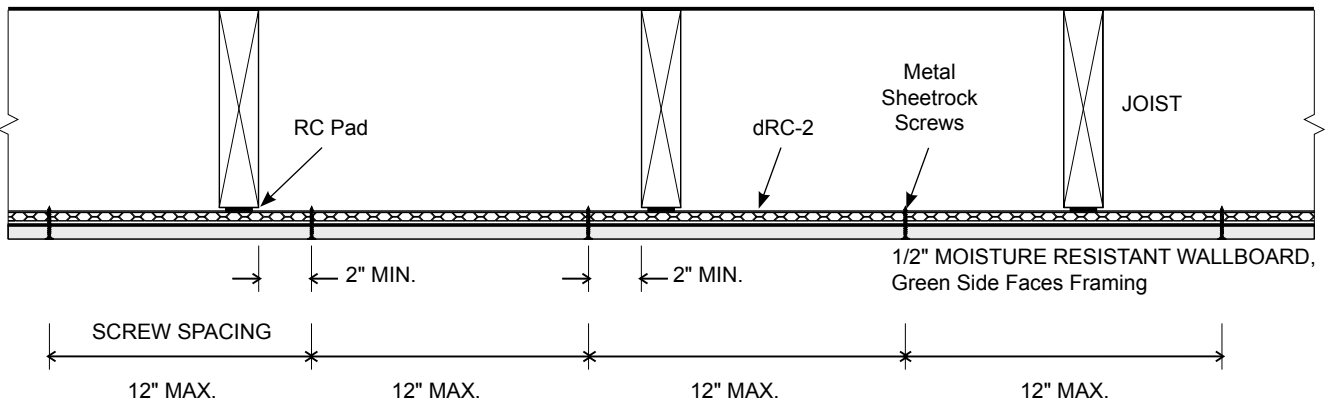

Fig. 4A CEILING SECTION

**Apply WallDamp**

[10] Remove release paper from one side of the **WallDamp Strips**. Apply the strips over all the wallboard joint seams as well as around the ceiling perimeter. Be sure to read **Install Technique** information on page 4.

[11] Use chalk line to lay out your grid for WallDamp Square placement.

[12] Remove release paper from one side of the **WallDamp Squares**, starting about 6" in from the edges, apply the Squares to wallboard surface 12" on centers. Use rubber mallet if necessary (Fig. 5A). Be sure to read **Install Technique** information on page 4.

**Note:** Joints between the two layers of wallboard should be staggered, and centered over WallDamp Squares). Identify and mark where the joint seams will be.

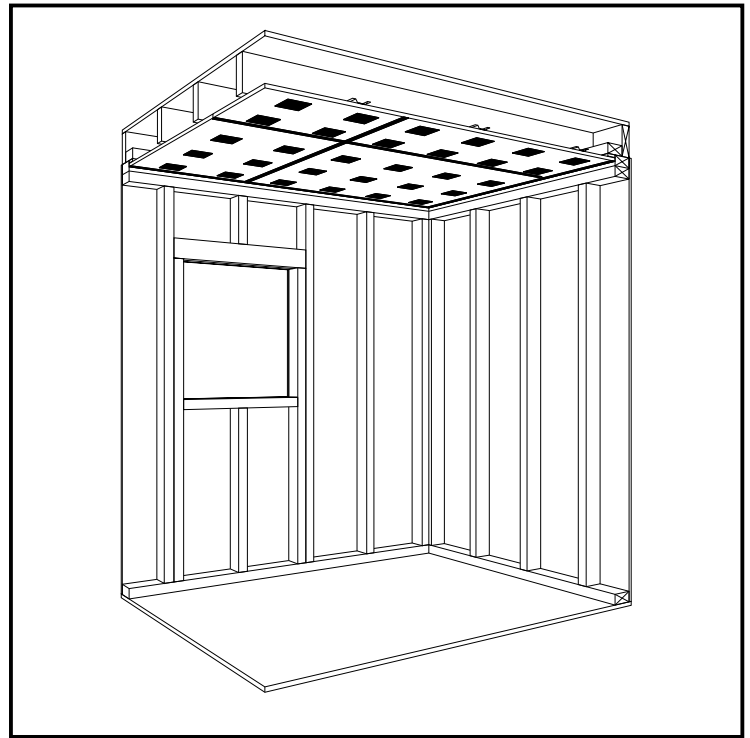

Fig. 5 CEILING INSTALLATION (cont'd)

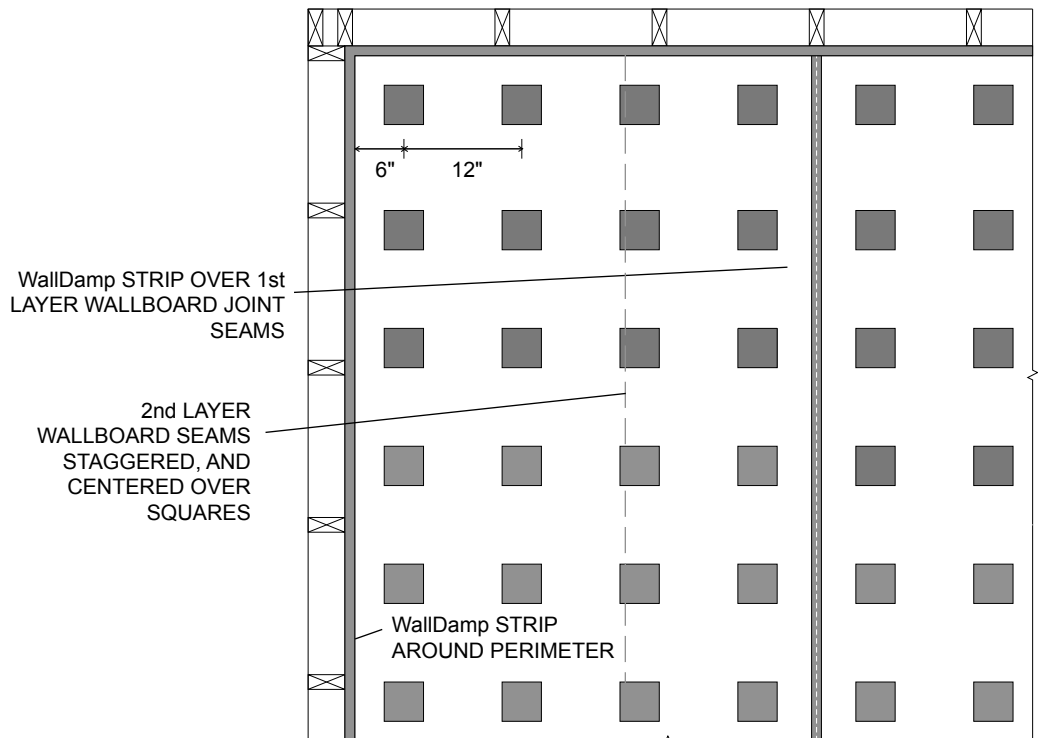

Fig. 5A CEILING PLAN



**Install Second Layer of Sheetrock**

[13] Attach 1/2" regular wallboard to **dRC-2s** through the first layer Moisture Resistant wallboard with 1-3/4" drywall screws 12" (max.) on centers. Use sheetrock screws for metal. Avoid driving the screws to joists by keeping the screws a minimum 2" distance from joists. (Fig. 6A).

**Note:** We recommend this layer should go the same direction as the first layer (perpendicular to **dRC-2s**) with the seams staggered.

Place the tapered finished side of the board toward the interior of the room.

At the perimeter, use sheetrock screws for wood to screw wallboard to ceiling nailing blocks 12" (max.) on centers through first layer wallboard and **Perimeter Gasket** strips. Be sure screws penetrate wood at least 1/2".

A 1/4" gap should be kept between ceiling wallboard and the top plates. Apply a bead of **Acoustical Sealant** to seal the gap.

**This completes your Ceiling Installation, now let's go on to the Wall Installation.**

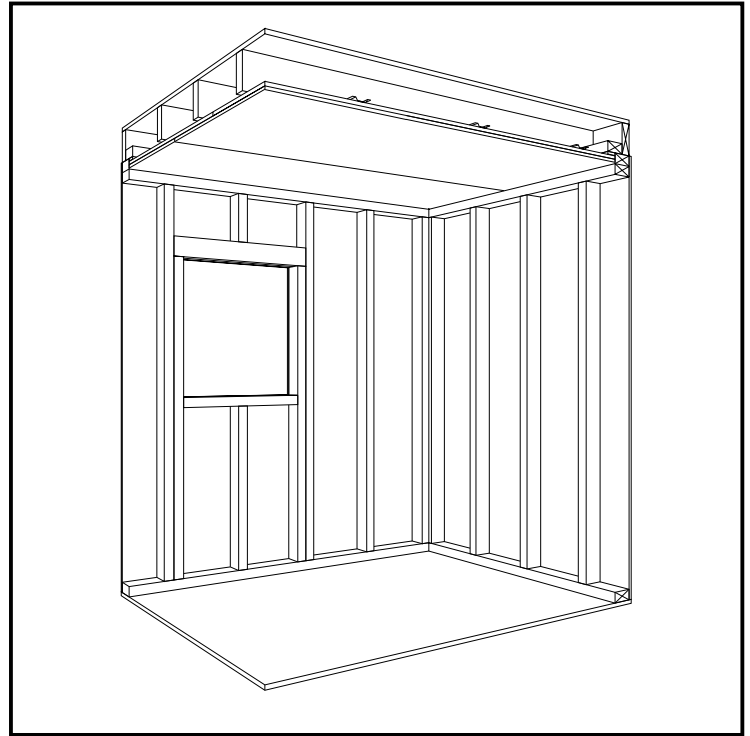

Fig. 6 CEILING INSTALLATION (cont'd)

**Avoid Driving Sheetrock Screws into Framing**

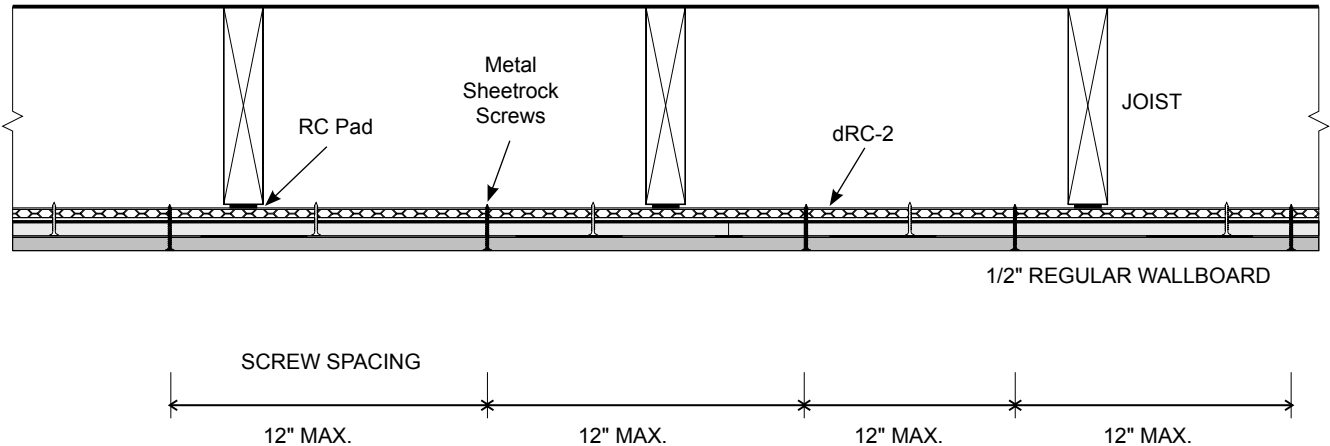

Fig. 6A CEILING SECTION

# IsoDamp Wall Install

(Contractors see page 16)

## Materials We Supply

**WALLDAMP SQUARES**

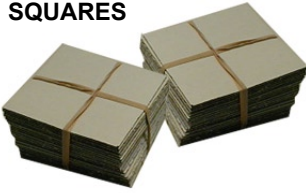

**WALLDAMP STRIPS**



**RC PADS**



**ACOUSTICAL SEALANT**



**dRC-1 Damped Resilient Channel for Walls**



**PERIMETER GASKET**



**WALL BEARING FELT**



## Required Materials You Supply

**CONSTRUCTION ADHESIVE**



**INSULATION BLANKET**



**TACK NAILS**



**MASKING TAPE**



**WIRE INSULATION SUPPORTS**



**1-1/4" & 1-3/4" DRYWALL SCREWS**



**3/8" TYPE S PAN HEAD SCREWS**



**1/2" REGULAR WALLBOARD**



**1/2" MOISTURE RESISTANT GYPSUM WALLBOARD**

**SPRAY ADHESIVE**



**MALLET WITH PADDING**



## IsoDamp Wall Prep

### Electrical outlets, light switches, and other in-wall fixtures:

It's a good idea to plan ahead before you begin your IsoDamp installation. The final wall thickness in the system is roughly 1-5/8" from the face of the studs. Place electrical and other junction boxes accordingly.

When installing the wallboard in the IsoDamp system, leave a 1/4" gap around any fixtures. Later, these gaps will be filled with acoustical sealant. This is the same method used for sealing around the wall/ceiling perimeter edges.

When you have finished installing the system, apply another bead of acoustical sealant to the edges of each fixture, prior to applying any faceplates or coverings.

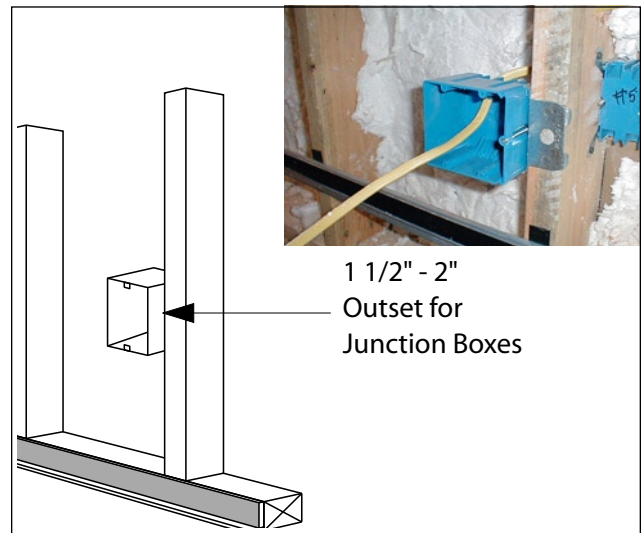

1 1/2" - 2" Offset for Junction Boxes

**JUNCTION BOX INSTALLATION**

# Wall Installation

## Install Insulation and Wall Bearing Felt

[1] Begin by pressing insulation blanket into stud cavity. The paper or foil backing should either be glued to the wallboard with spray adhesive or it should be removed. If necessary, use wire insulation supports every 12" to 16" to hold up the blanket.

[2] Remove release paper from the 1-1/2" **Wall Bearing Felt** and glue it on floor around perimeter of room. Secure the Felt with tack nails if needed. Caulk with **Acoustical Sealant** below Felt if floor is irregular.

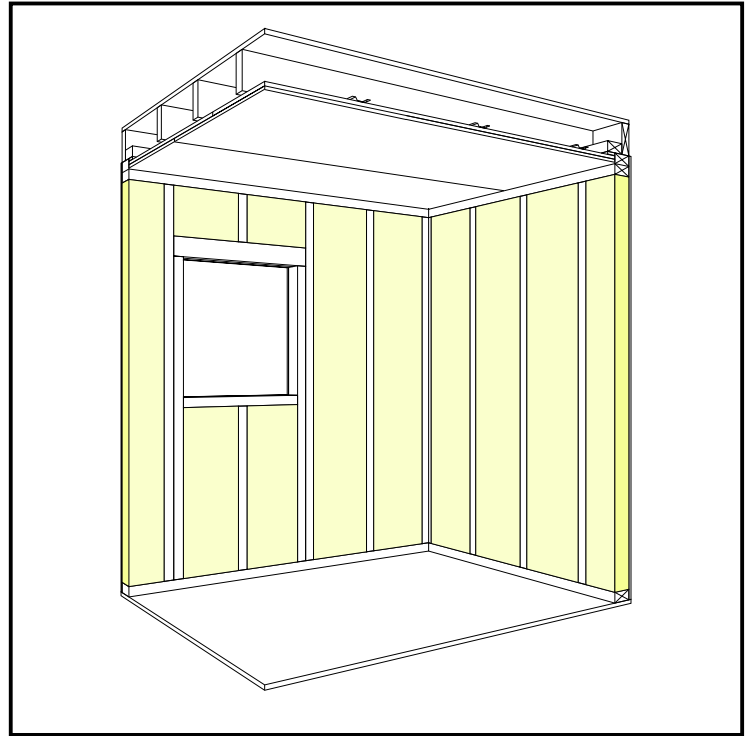

Fig. 7 WALL INSTALLATION

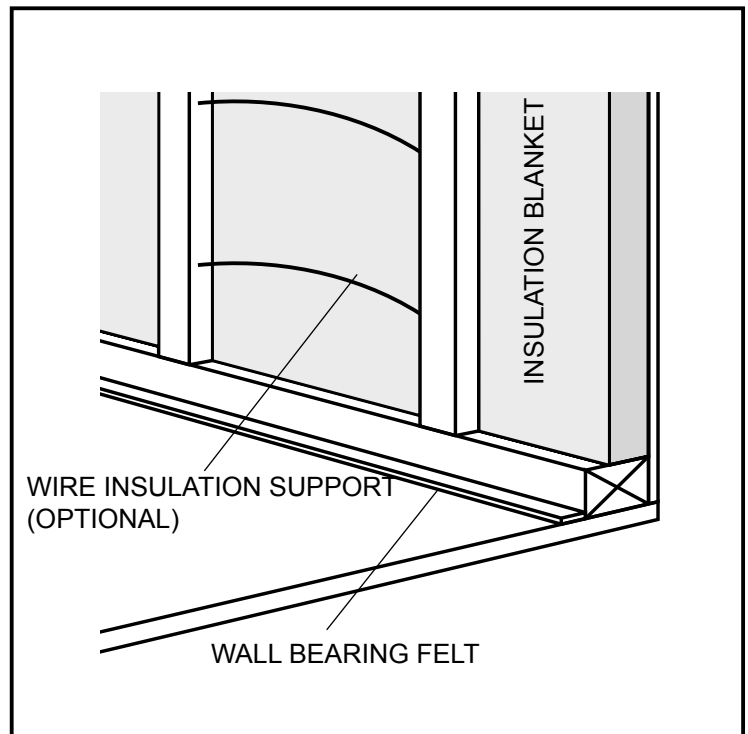

Fig. 7A DETAIL

### Install Perimeter Gasket

[3] With a urethane panel adhesive such as Liquid Nails™, glue **Perimeter Gasket** strips onto edge of top /sole plates around wall perimeter as well as around openings, such as door and window headers, sills, etc. Use tack nails (if needed) as extra holding strength while the adhesive dries.

[4] Determine resilient channel placement based on Fig. 9A on page 11. Mark locations using a chalk line.

### Install RC Pads

[5] Remove release paper on one side of 1 1/2" x 3" **RC Pads** and apply them to the face of the studs where **dRC-1**'s will be screwed on. (Fig. 8A). Be sure to read **Install Technique** information on page 4.

Remove remaining release paper.

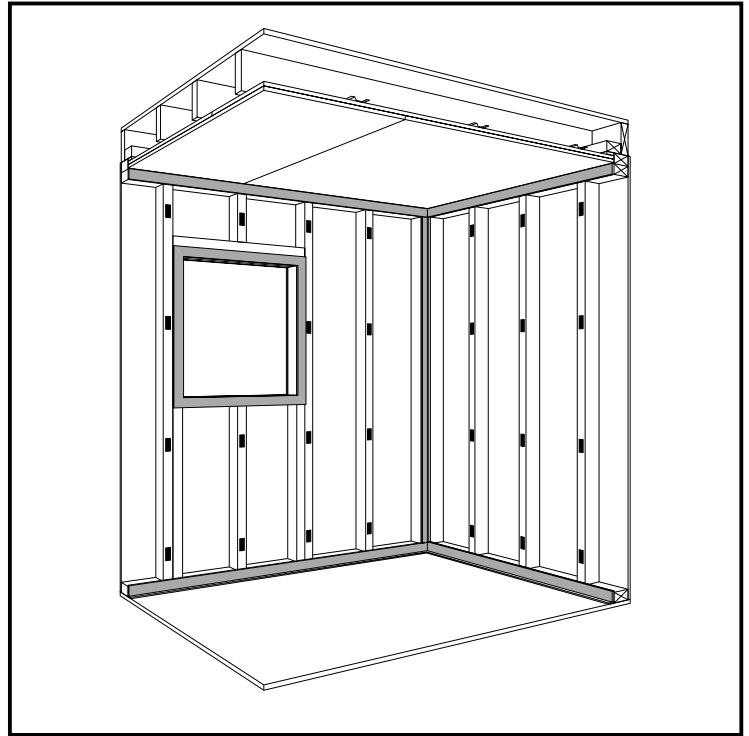

Fig. 8 WALL INSTALLATION (cont'd)

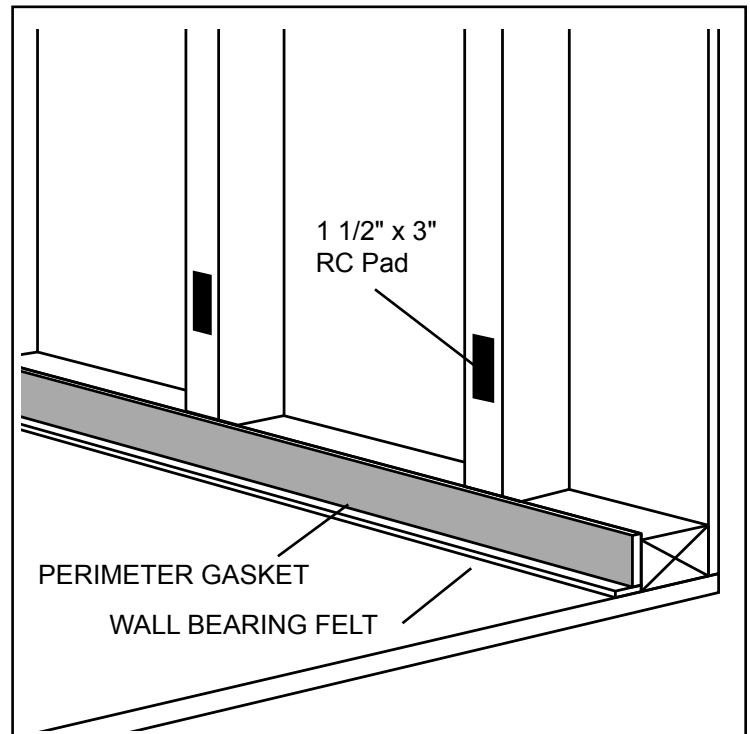
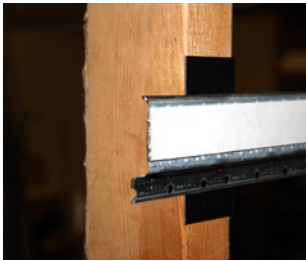

Fig. 8A DETAIL

**Install Resilient Channel**

[6] Fasten **dRC-1** (leg flange down) perpendicular to studs with 1-1/4" drywall screws at each stud.



Channel spacing should be 24" (max.) when stud spacing is 16", or 16" (max.) for 24" stud spacing. Top and bottom Channels should be 12" from floor or ceiling. Channel ends should be held back from

intersecting surfaces but cantilevered no more than 6" from studs. (Fig. 9A)

Splice channels directly over studs by overlapping (not butting) at least 1-1/2" and driving screws through both channels into the studs (Fig. 9B). If channel overlap falls between studs, overlap channels at least 6" and fasten both channels near ends with 3/8" Type S Pan Head Screws. (Fig. 9C)

**TIP:** Mark the location of the studs and the **dRC-1s** on floor and ceiling with masking tape at the ends of each stud. This will be helpful for later installation.

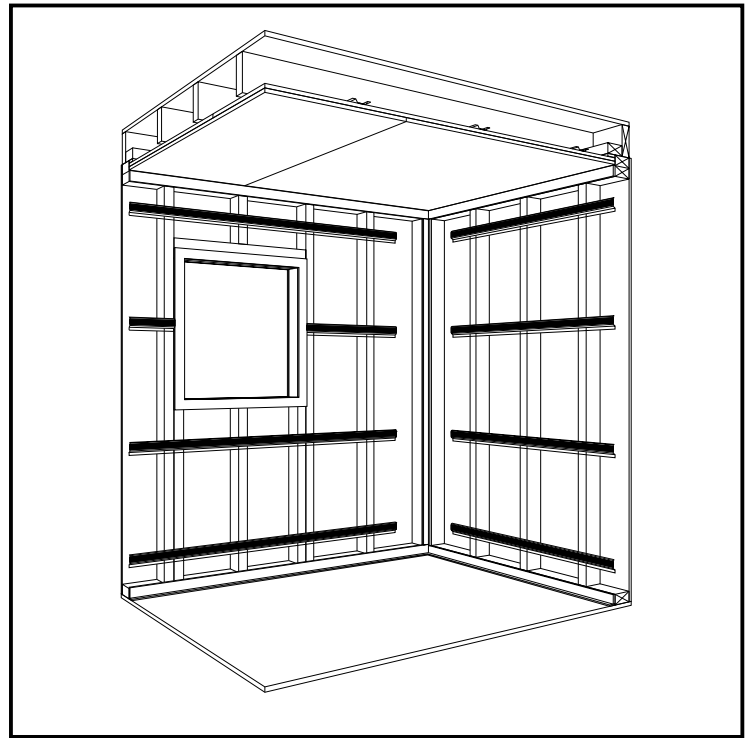

**Fig. 9 WALL INSTALLATION (cont'd)**

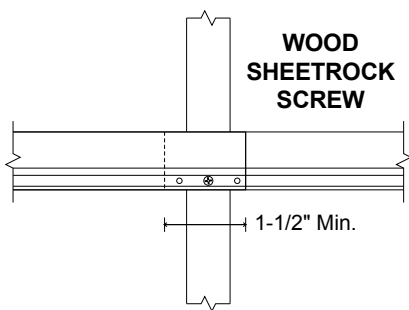

**Fig. 9B SPLICE CHANNELS OVER STUD**

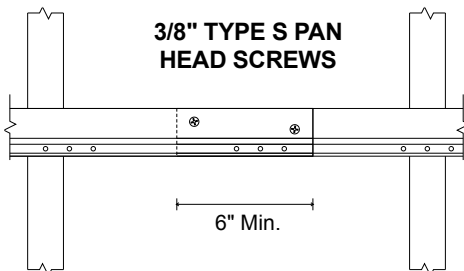

**Fig. 9C SPLICE CHANNELS BETWEEN STUDS**

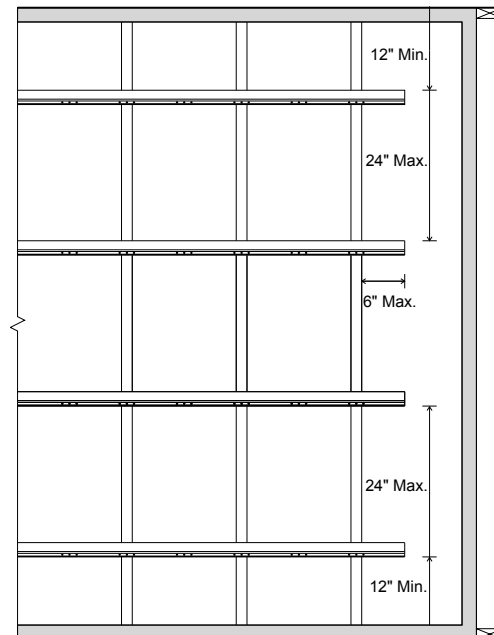

**Fig. 9A WALL ELEVATION**

**Install First Layer of Sheetrock**

[7] Apply 1/4" bead panel adhesive to face of the installed **Perimeter Gasket** strips.

[8] Snap chalk lines on the wallboards to mark the location of the studs and the **dRC-1s**.

[9] Attach 1/2" Moisture Resistant wallboard perpendicular to **dRC-1s** with drywall screws for metal, 12" (max.) on centers. Avoid driving the screws to studs by keeping the screws a minimum 2" distance from studs (Fig. 10A).

**Note:** Place the green side of the first layer board toward the framing, brown side facing out\*.

At the perimeter, use sheetrock screws for wood to screw wallboard to ceiling nailing blocks 12" (max.) on centers through first layer wallboard and **Perimeter Gasket** strips. **Be sure screws penetrate wood at least 1/2".**

A 1/4" gap should be kept between the wall and ceiling as well as all adjacent walls. Apply a bead of **Acoustical Sealant** to seal the gap.

[10] Decide and visualize the layout for the second layer wallboard. We recommend this layer should go the same direction as the first layer (perpendicular to **dRC-1s**). Joints between the two layers should be staggered, and centered over WallDamp Squares). Identify and mark where the joint seams will be.

**Note:** If the second layer of wallboard needs to be orientated parallel to the **dRC-1s** (opposite the first layer), be sure to space the **dRC-1s** so the second layer wallboard seams align centered over the **dRC-1s**.

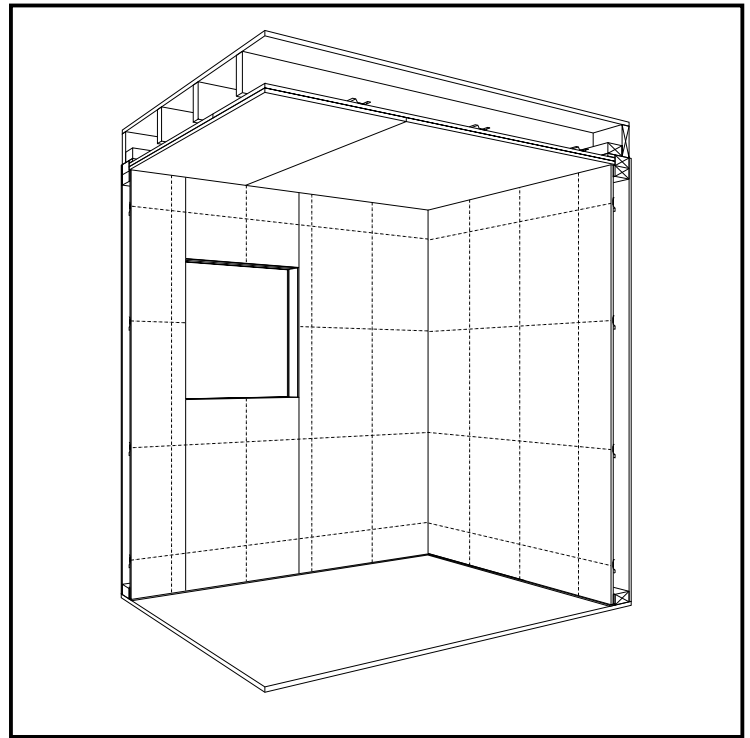

**Fig. 10 WALL INSTALLATION (cont'd)**

\* Green side has tapered edges which prohibit adequate contact with WallDamp strips.

**Avoid Driving Sheetrock Screws into Framing**

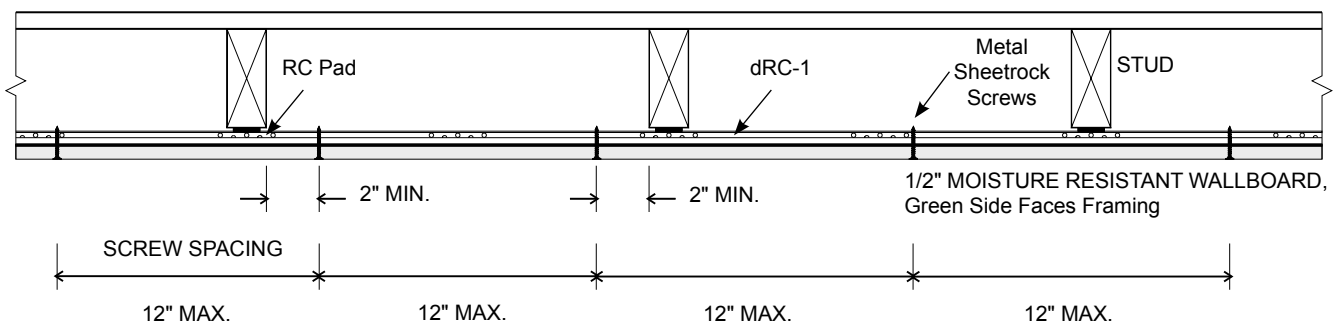

**Fig. 10A TOP VIEW, WALL SECTION**

**Install WallDamp**

[11] Remove release paper from one side of the **WallDamp Strips**. Tape the strips over all the joint seams as well as perimeter of walls and openings. (Fig. 11A). Be sure to read **Install Technique** information on page 4.

[12] Determine placement of WallDamp Squares starting about 6" from the wall edges and 12" on center within the field. Snap chalk lines to help speed application. Remove release paper from one side of the **WallDamp Squares** and apply. Use mallet if necessary. Be sure to read **Install Technique** information on page 4.

**Note:** Joints between the two layers of wallboard should be staggered, and centered over WallDamp Squares). Identify and mark where the joint seams will be.

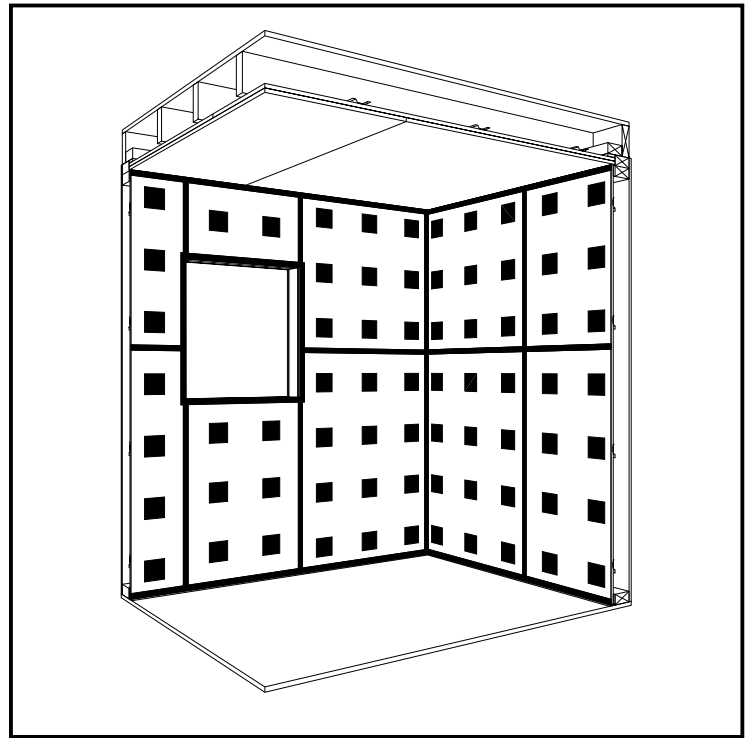

Fig. 11 WALL INSTALLATION (cont'd)



2nd LAYER WALLBOARD SEAMS STAGGERED, AND CENTERED OVER SQUARES

WallDamp STRIP OVER 1st LAYER WALLBOARD JOINT SEAMS

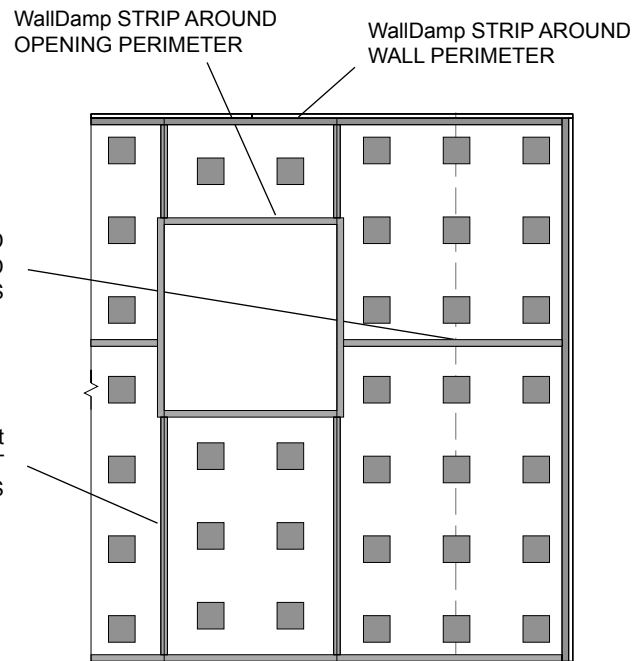

Fig. 11A WALL ELEVATION

**Install Second Layer of Sheetrock**

[13] Attach 1/2" regular wallboard perpendicular to **dRC-1s** through the first layer Moisture Resistant wallboard with drywall screws for metal, 12" (max.) on centers. Avoid driving the screws to studs by keeping the screws a minimum 2" distance from studs. Se Fig. 10A on page 12.

**Note:** Place the tapered finished side of the board toward the interior of the room.

At the perimeter, use sheetrock screws for wood to screw wallboard to ceiling nailing blocks 12" (max.) on centers through first layer wallboard and **Perimeter Gasket** strips. Be sure screws penetrate wood at least 1/2".

A 1/4" gap should be kept between wallboard and the corner studs, or other framing members. Apply a bead of **Acoustical Sealant** to seal the gap.

[14] Tape and apply drywall joint compound to wall and ceiling.

**Congratulations, you are now done!**

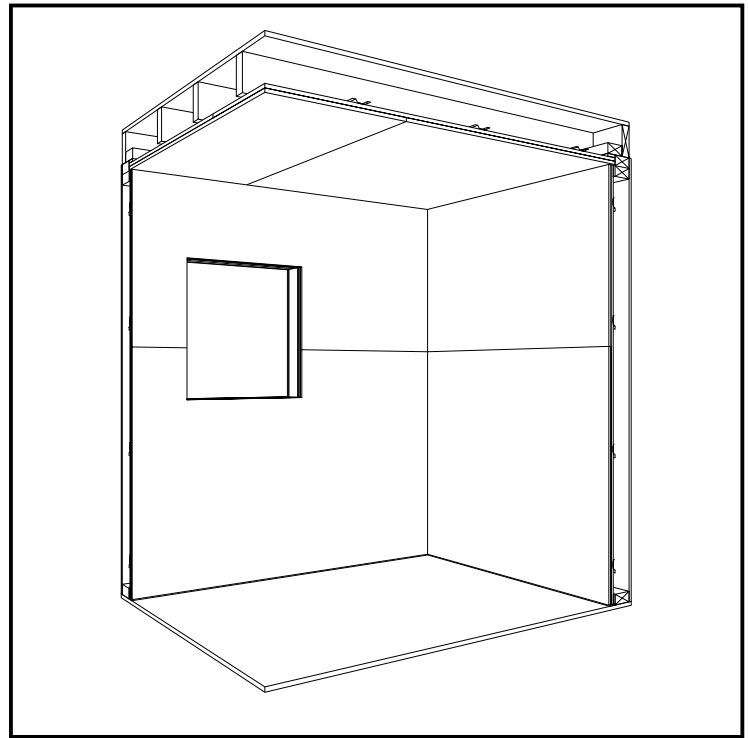
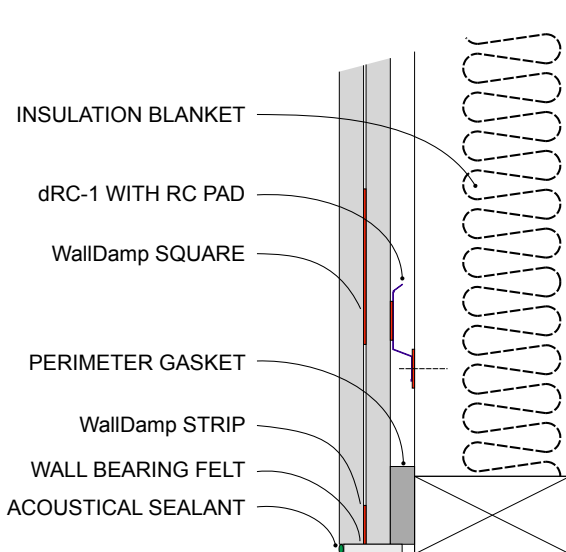
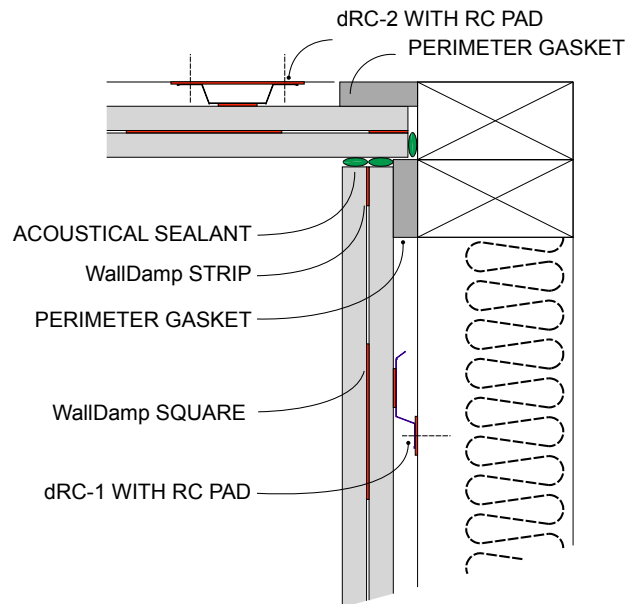

Fig. 12 WALL INSTALLATION (cont'd)

**IsoDamp System Overview**



SECTION - WALL / FLOOR DETAIL



SECTION - WALL / CEILING DETAIL



**Local Codes Super cede Our Guidelines**

Always follow local building codes, even if we suggest something contrary. Just make sure to adhere to the basic principle of isolating walls and ceilings from the framing.

**Feel Free to Incorporate Time Saving Techniques**

If you prefer to work from a stack of sheetrock on the floor, by all means do so. The overhead application of WallDamp Squares and Strips to ceilings is tough work. On large commercial projects where the benefits of WallDamp is desired, it may be easier for you to apply WallDamp on each sheet before installing it instead of after. There is no hard and fast rule as long as the end result is the same.

As for application of WallDamp be sure to use a rubber mallet to help set the adhesive along.

**Always Peel the Backing Paper**

When a crew gets into the production mind set, its easy to overlook the pesky backing paper. Before you know it, 5 or 6 sheets of rock have gone up and now you're looking at white squares. Just remove the sheetrock, remove the backing paper and reinstall the rock.

**Clean up as you work**

The Teflon coated paper is slippery. Boots are no protection either since this stuff is totally anti-friction. Better to have a job site trash can on hand while peeling WallDamp backing paper.

**Don't Hang RC Channel Upside Down**

We see some confusion on the advantages to which way to mount RC channel. It's supposed to be mounted with the long leg up, short leg down. However, once positioned correctly, its easy and fast to cruise through the process.

